

# Rack Mounting Solutions

Connect. Protect. Equip



Equip offers a comprehensive range of premium passive networking products, including cabling, mounting solutions, and networking infrastructure, serving installation companies, end-customers, and retail. Recently, we expanded our portfolio to include server and network cabinets, reinforcing our commitment to providing complete networking solutions.



# Introduction

Equip presents a selection of cabinets for a variety of settings, from the simplicity of office installations to the rigors of outdoor environments. Our range includes the Basic Flex, Dynamic Flex, Eco Wall Mount, Pro Wall Mount, Safe Outdoor, and Slim Flex lines, each designed with practicality and efficiency in mind. Built from quality steel, these cabinets offer solid stability and a clean aesthetic that fits into any space.

At the heart of our designs is a focus on streamlined cable management and flexible configurations to support both active and passive network components. From the easily adjustable profile rails in our Basic and Dynamic Flex lines to the rugged, weather-resistant features of our Safe Outdoor cabinets, we've considered the needs



of users across different scenarios. The Eco Wall Mount, Pro Wall Mount and Slim Flex lines offer to those seeking reliable, space-saving solutions with easy installation.

Equip's approach is grounded in offering straightforward, reliable products that do their job well without unnecessary frills. We believe in making our customers' work easier through thoughtful design and durable construction, ensuring each cabinet line provides a practical solution for today's networking challenges. Explore our offerings to find the right fit for your needs, knowing that behind each Equip cabinet is a commitment to simplicity and functionality.

# Content

---

- 05 Cabinet Closeups
- 08 Basic Flex Cabinet Line
- 10 Dynamic Flex Cabinet Line
- 12 Wall Mounts Eco Line
- 14 Wall Mounts Pro Line
- 16 Wall Mount Slim Line
- 17 Safe Outdoor Line
- 18 Cabinet Accessories
- 20 Patch Panels
- 22 PDUs
- 23 Shelves + Drawers



# Explanation of the Equip Codes/Names

At Equip, our cabinet naming system is as intuitive as the design of our products. The model name of each cabinet is a blend of abbreviation and specification that together provide a clear, quick reference to the product's key features. For instance, let's decipher the code "EBF-22-6060-B-BAAA":

"BF" stands for the product line, in this case, the Basic Flex line, indicating the foundational series of our product range.

The first number, "22," represents the height of the cabinet in units (U), a standard measure in rack mounting that denotes the vertical space available.

The second set of numbers, "6060," details the depth and width of the cabinet, providing immediate insight into the size and space it occupies.

The letter "B" following the size indicates the color of the cabinet. In this nomenclature, "B" stands for black, aligning with the RAL color code 9005.

The final set of letters, "BAAA," specify various features or configurations unique to this cabinet model, such as the type of doors and side panels.

This straightforward system ensures that at a glance, the user or installer can understand the essential characteristics of the cabinet, facilitating selection and ensuring compatibility with their specific needs. It's a reflection of Equip's commitment to efficiency and user-friendliness, from our product design right through to our product naming.

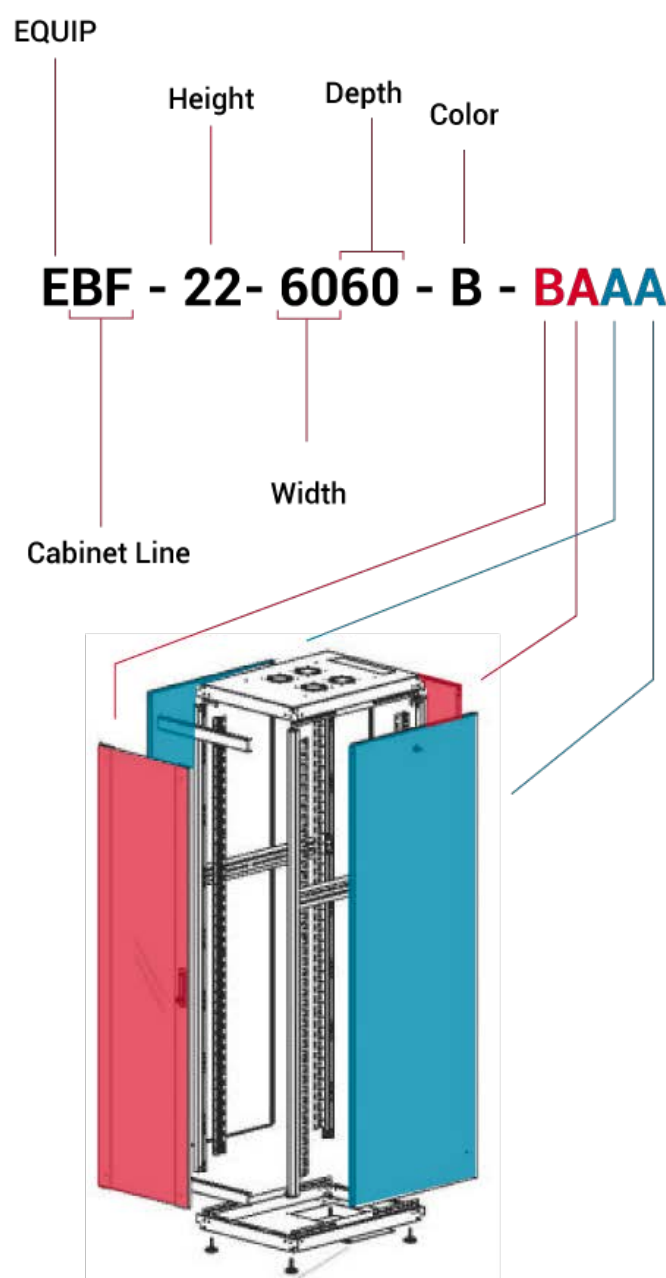

# Basic Flex Line

The cabinets of the **Basic Flex Line** are engineered for the efficient and user-friendly installation of both active and passive network components, prioritizing streamlined cable management. Crafted from steel sheets up to 1.5 mm thick, every cabinet guarantees excellent stability, attributed to a unique plate curving technique, forming a sturdy steel framework.

The Basic Flex cabinets are finished with a powder coating in shades of grey (RAL 7035) and black (RAL 9005).

For challenging set-up locations that are less accessible, the cabinet is designed to be disassembled. The doors are easily detachable, and their stops can be switched between right and left orientations. Additionally, the roof is prepped for the integration of an air ventilation unit. Inside, each cabinet houses two sets (4 pieces) of 483 mm (19") profile rails. These rails, galvanized and marked with height units readable from both directions, are adjustable in depth. To facilitate extensive equipment installations, they're paired with supplementary depth support bars.

Cable management is central to the design. The cabinet base features a punched-out cable entry shielded with a metal plate. For the broader 800 mm width cabinets, there are added punched-out cable entries covered with plastic on both sides. These entries are replicated on the roof, with one for 600 mm width cabinets and three for the 800 mm width ones. To cater to diverse operational needs, a wide assortment of accessories, including cable management tools and shelves, is readily available.



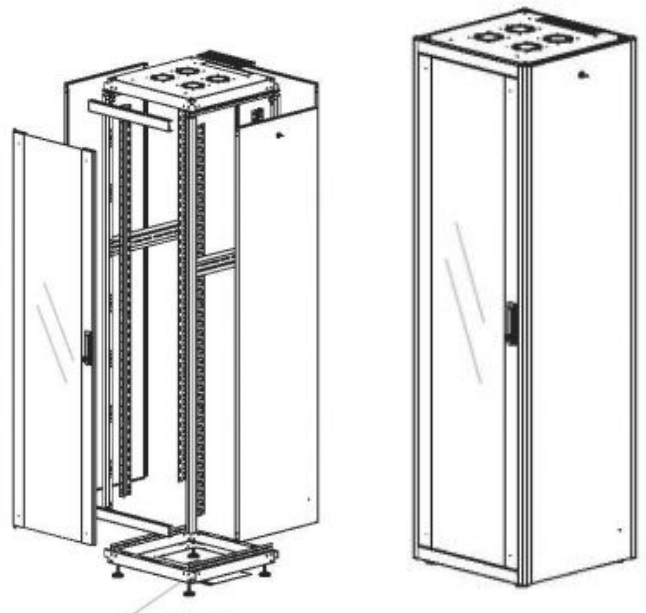
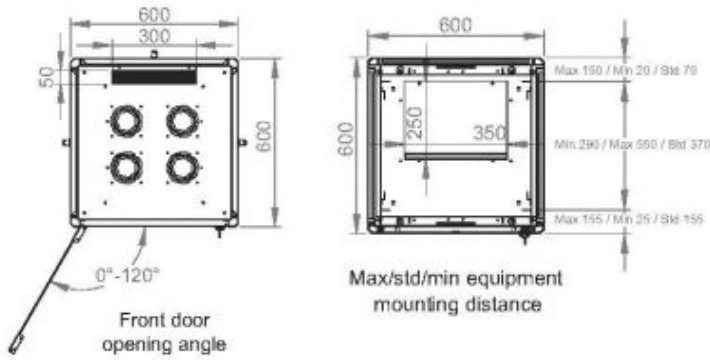

EQUIP NUMBER	EQUIP CODE	HEIGHT	WIDTH	DEPTH	COLOR		
280001	EBF-22-6060-B-BAAA	22U	60	60	Black		
280002	EBF-22-6060-G-BAAA				Grey		
280003	EBF-22-6080-B-BAAA		80	80	Black		
280004	EBF-22-6080-G-BAAA				Grey		
280005	EBF-22-8080-G-BAAA				Grey		
280006	EBF-26-6010-B-CCAA	26U	60	10	Black		
280007	EBF-26-6010-G-CCAA				Grey		
280008	EBF-26-6060-B-BAAA			60	60	Black	
280009	EBF-26-6060-G-BAAA					Grey	
280010	EBF-26-6080-G-BAAA					Grey	
280011	EBF-32-6060-G-BAAA	32U	60	60	Grey		
280012	EBF-32-6080-B-BAAA				80	80	Black
280013	EBF-32-6080-G-BAAA						Grey
280014	EBF-32-8080-G-BAAA		80	80	Black		
280015	EBF-32-8080-G-BAAA				Grey		
280016	EBF-42-6010-B-CCAA	42U	60	100	Black		
280017	EBF-42-6010-G-BAAA				Grey		
280018	EBF-42-6010-G-CCAA				Grey		
280019	EBF-42-6060-B-BAAA			60	60	Black	
280020	EBF-42-6060-G-BAAA					Grey	
280021	EBF-42-6080-G-BAAA		80	80	Grey		
280022	EBF-42-6080-G-BBAA				Grey		
280023	EBF-42-8010-B-CCAA				100	100	Black
280024	EBF-42-8010-G-BAAA	Grey					
280025	EBF-42-8010-G-CCAA	Grey					
280027	EBF-42-8080-B-BAAA	80	80	Black			
280028	EBF-42-8080-G-BAAA			Grey			

# Dynamic Flex Line

Introducing the “**Dynamic Flex Line**” Cabinets: Designed for user-friendly installation of active and passive network components, these cabinets prioritize efficient cable management. Constructed from steel sheets up to 1.5 mm thick, each cabinet ensures exceptional stability, thanks to a unique plate curving technique.

The Dynamic Flex cabinets of Equip are elegantly finished with a powder coating in shades of grey (RAL 7035) and black (RAL 9005).

In scenarios where the installation location is hard to access, the cabinet can be effortlessly disassembled. Its doors are designed for easy removal, with the flexibility to switch the doorstop's orientation from right to left. The cabinet's roof features an additional lid, equipped with air ventilation slots to promote better airflow. It's also prepped for the addition of an air ventilation unit.

Internally, each cabinet boasts two sets (4 pieces) of 483 mm (19") profile rails, which are galvanized and feature height unit markings readable from both directions. These rails are adjustable in depth and come with extra depth support bars, ensuring comprehensive 483 mm (19") equipment installations.

A highlight of the design is the emphasis on cable management. The cabinet base incorporates a sliding cable entry panel sealed with rubber. Cabinets of 26U and above are outfitted with two cable entries featuring brush strips at the rear, both above and below the door.

The 800 mm width cabinets offer advanced cable management options, including additional cable entries with brushes on the top and base.

Additionally, these wider cabinets include vertical cable ducts with shutters on both sides, adjacent to the 483 mm (19") profile rails in the front. To address diverse operational needs, a comprehensive range of accessories, including cable management tools and shelves, is available, ensuring adaptability in everyday use.





EQUIP NUMBER	EQUIP CODE	HEIGHT	WIDTH	DEPTH	COLOR
280701	EDF-16-6080-G-BMAA	16U	60	80	Grey
280702	EDF-22-6060-B-BMAA	22U	60	60	Black
280703	EDF-22-6060-G-BMAA				Grey
280704	EDF-22-6080-B-BMAA			80	Black
280705	EDF-22-6080-G-BMAA				Grey
280706	EDF-22-8080-B-HNAA		80	80	Black
280707	EDF-22-8080-G-HNAA			Grey	
280708	EDF-26-6060-B-BIAA		26U	60	60
280709	EDF-26-6060-G-BIAA	Grey			
280710	EDF-26-6080-B-BIAA	80			Black
280711	EDF-26-6080-G-BIAA				Grey
280715	EDF-26-8080-G-HJAA	80		80	Grey
280712	EDF-26-8010-B-HJAA			100	Black
280713	EDF-26-8010-G-HJAA				Black
280716	EDF-32-6060-B-BIAA	32U	60	60	Grey
280717	EDF-32-6060-G-BIAA				Grey
280718	EDF-32-6080-B-BIAA			80	Black
280719	EDF-32-6080-G-BIAA				Grey
280720	EDF-32-8080-B-HJAA		80	80	Black
280721	EDF-32-8080-G-HJAA			Grey	
280722	EDF-36-6060-B-BIAA		36U	60	60
280723	EDF-36-6060-G-BIAA	Grey			
280724	EDF-36-6080-G-BIAA	80			Grey
280727	EDF-42-6060-B-BIAA	42U	60	60	Black
280728	EDF-42-6060-G-BIAA				Grey
280729	EDF-42-6080-B-BIAA			80	Black
280730	EDF-42-6080-G-BIAA				Grey
280725	EDF-42-6010-B-BIAA			100	Black
280726	EDF-42-6010-G-BIAA				Grey
280731	EDF-42-8010-B-HJAA		80	100	Black
280733	EDF-42-8010-G-HJAA				Grey
280734	EDF-42-8012-G-HJAA			120	Grey
280740	EDF-47-6080-G-BIAA				47U
280737	EDF-47-6010-G-BIAA	100	Grey		
280741	EDF-47-8080-G-HJAA	80	80	Grey	

# Wall Mount Eco Line

Introducing the **Equip Eco Mount Wall Mount Cabinets**, engineered for seamless installation and efficient management of your network components, all while prioritizing elegant cable organization.

The Eco Wall Mounts come as a semi flat-pack solution for safer and more ergonomic logistics. The mounts are super easy to install and come with a manual and a short support video.



Crafted from robust steel sheets up to 1.5 mm thick, these cabinets stand as symbols of durability and strength, ensuring your valuable equipment remains secure. Available in sophisticated shades of grey (RAL 7035) and black (RAL 9005), our cabinets offer both functionality and aesthetics.

Whether you choose the 10' or 19' variant, the Equip Eco Mount series provides a hassle-free experience, whether wall-mounted or configured as standalone units. The door and side panels are designed for effortless detachment, and you have the flexibility to switch the door's orientation from right to left for your convenience.

To enhance airflow and maintain an optimal operating environment, our cabinets feature integrated ventilation slots on the roof. Inside, you'll find a pair of pre-mounted 483 mm (19") profile rails, adjustable

in depth, and complete with readable height unit markings from both directions. The back frame includes 483 mm (19") punch-outs for added versatility. Efficient cable management is at the forefront of our design. The roof includes a sliding cable entry panel with a rubber seal for ease of access and organization. Punched-out cable entries with protective plastic covers are strategically placed on the rear wall and base.

Additionally, the rear frame is equipped with brushes on both the top and bottom to keep your cables tidy and well-organized. Our commitment to flexibility extends to a wide range of accessory options, including cable management tools and shelves, designed to meet diverse operational demands.

With the Equip Eco Mount Wall Mount Cabinets, you can optimize your IT infrastructure with confidence, knowing that your equipment is housed securely and efficiently. Choose Equip Eco Mount for a smarter, more organized, and reliable network cabinet solution, whether you need a 10' or 19' variant, and elevate the performance of your IT environment today.



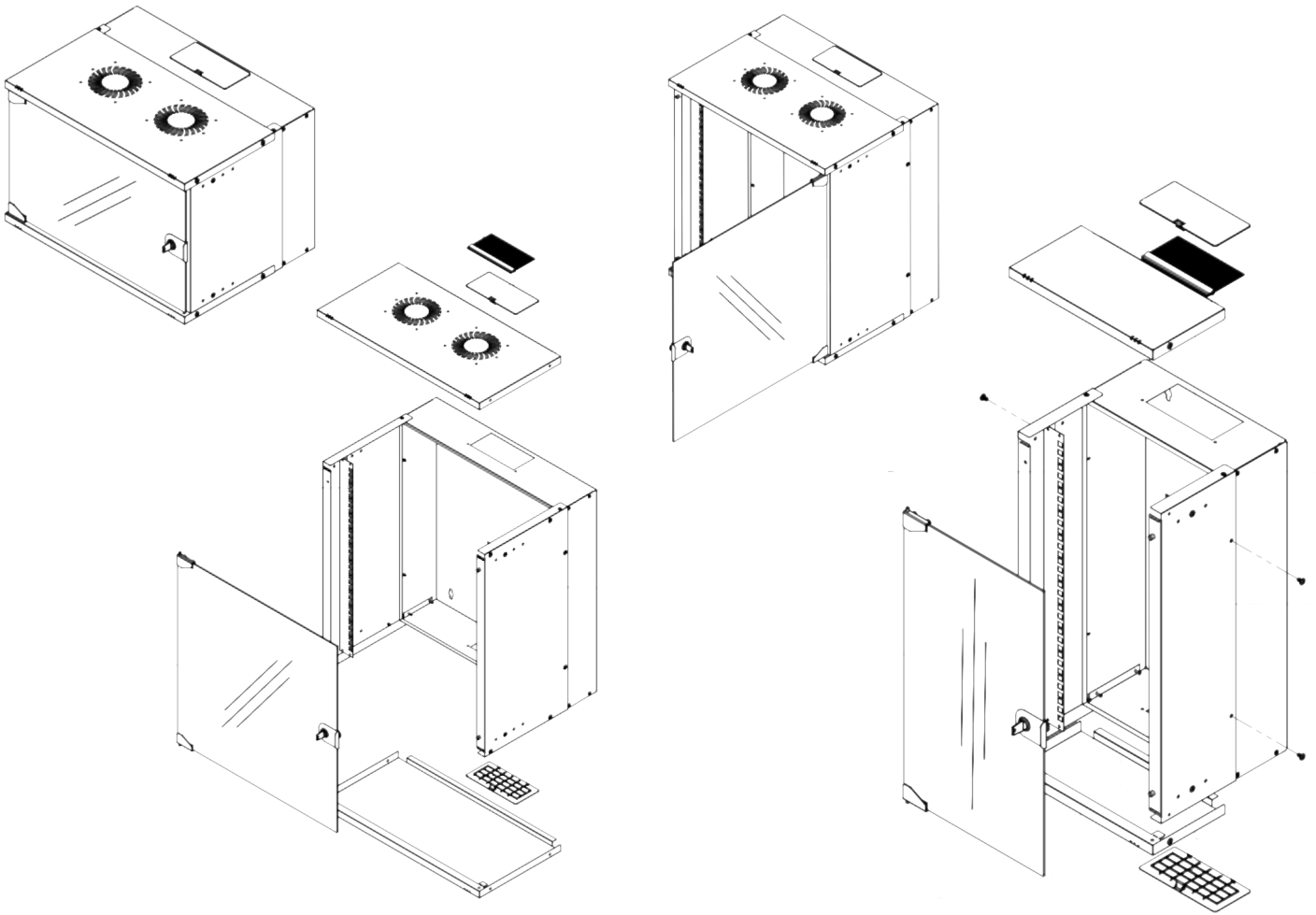

EQUIP NUMBER	EQUIP CODE	HEIGHT	WIDTH	DEPTH	COLOR
0	EWM-04-5440-B	4U	54	40	Grey
280321	EWM-04-5440-G				Black
280315	EWM-06-3030-B	6U	30	30	Grey
280316	EWM-06-3030-G				Black
280322	EWM-07-5440-B	7U	54	40	Grey
280323	EWM-07-5440-G				Black
280317	EWM-09-3030-B	9U	30	30	Grey
280318	EWM-09-3030-G				Black
280324	EWM-09-5440-B		54	40	Grey
280325	EWM-09-5440-G				Black
280319	EWM-12-3030-B	12U	30	30	Grey
280320	EWM-12-3030-G				Grey
0	EWM-12-5440-B		54	40	Black
280314	EWM-12-5440-G				Black

# Wall Mount Pro Line

Our Wall Mounting 'Pro Mount' Cabinets are tailored for a hassle-free and efficient setup of both active and passive network components, emphasizing sleek cable management. Constructed from steel sheets up to 1.5 mm thick, every rack stands out for its robustness and durability.

These cabinets are beautifully finished with a powder coating in shades of grey (RAL 7035) and black (RAL 9005). Wall mounting has been simplified for users, and for those preferring standalone configurations, individual levelling feet or castors are available.

The door and side panels are designed for easy detachment, with the option to switch the door's orientation from right to left. For enhanced air circulation, the roof features integrated ventilation slots. Each cabinet is equipped with a set of two pre-mounted 483 mm (19") profile rails. These rails are galvanized, feature height unit markings readable from both directions, and are adjustable in depth. The back frame also incorporates 483 mm (19") punch-outs.

Prioritizing efficient cable management, the roof boasts a sliding cable entry panel with a rubber seal. Punched-out cable entries with plastic covers are found on the rear wall and base, and the rear frame offers brushes on both the top and bottom. To fulfil a variety of operational demands, an extensive range of accessory options, such as cable management tools and shelves, is available.



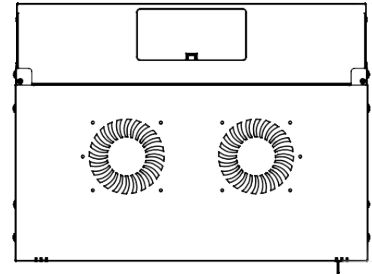
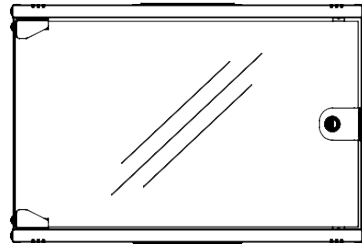
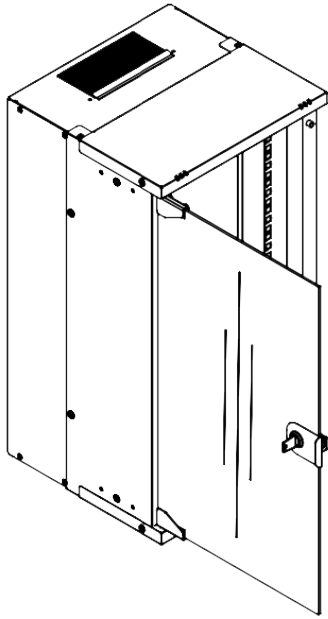

EQUIP NUMBER	EQUIP CODE	HEIGHT	WIDTH	DEPTH	COLOR
280108	EDF-16-6080-G-BMAA	7U	60	45	Black
280109	EDF-22-6060-B-BMAA				Grey
280110	EDF-22-6060-G-BMAA			60	Black
	EDF-22-6080-B-BMAA				Grey
280111	EDF-22-6080-G-BMAA				Grey
	EDF-22-8080-B-HNAA				Grey
280112	EDF-22-8080-G-HNAA	9U	60	45	Grey
280113	EDF-26-6060-B-BIAA				Black
	EDF-26-6060-G-BIAA			60	Grey
280114	EDF-26-6080-B-BIAA				Black
	EDF-26-6080-G-BIAA				Grey
280115	EDF-26-8080-G-HJAA	12U	60	45	Grey
280116	EDF-26-8010-B-HJAA				Black
280117	EDF-26-8010-G-HJAA			60	Black
280118	EDF-32-6060-B-BIAA				Grey
280105	EDF-32-6060-G-BIAA				Grey
280119	EDF-32-6080-B-BIAA	16U	60	45	Black
280120	EDF-32-6080-G-BIAA				Grey
280121	EDF-32-8080-B-HJAA			60	Black
280122	EDF-32-8080-G-HJAA				Grey
280106	EDF-36-6060-B-BIAA				Black
280123	EDF-36-6060-G-BIAA	20U	60	45	Grey
280124	EDF-36-6080-G-BIAA				Black
280125	EDF-42-6060-B-BIAA			60	Grey
280126	EDF-42-6060-G-BIAA				Black
280107	EDF-42-6080-B-BIAA				Grey

# Wall Mount Slim Line

The Slim Flex Wall Mounting Cabinets are ideal for housing both active and passive components. Designed for simplicity, they enable swift and hassle-free installations.

Their contemporary design seamlessly blends into office or home settings. Users are presented with dual installation options: The front side features a versatile 3U rail that can rotate vertically, be set horizontally, or even angled. The rear side has a fixed 2U rail, suitable for passive network components, for instance. The lower housing area has pre-punched mounting holes to accommodate non-rack-mountable equipment like DSL routers. Alternatively, a device mounting plate can be added, which is available separately.

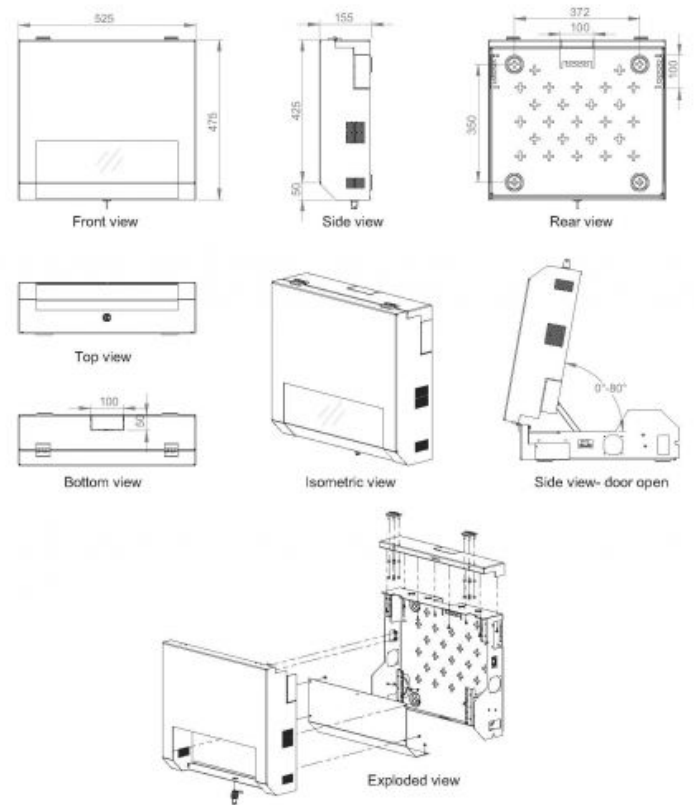

EQUIP NUMBER	EQUIP CODE	HEIGHT	COLOR
280401	ESF-05-B	2 U + 3 U	Black
280402	ESF-05-G	2 U + 3 U	Grey



# Safe Outdoor Line

The "Safe Outdoor" Cabinet Line presents the 483 mm (19") IP55 Outdoor Wall Mount Cabinets, tailored for industrial use. Adhering to the IP55 safety standard as per EN 60529, they offer resistance against both water and dirt infiltration.

Enhanced security is ensured with a 3-point-locking system complemented by a lockable swing handle and insulated cable entry points. The cabinets also feature integrated air ventilation slots for fresh air circulation, maintaining protection against water and dust as per IP54 standards.

These cabinets are ideal for locations exposed to environmental elements like rain, dust, sleet, snow, and splashing water. For more flexibility, these cabinets can be paired with a plinth for standalone setups. When using the plinth, rear mounting holes can be sealed using plugs sourced from the cabinet's base.

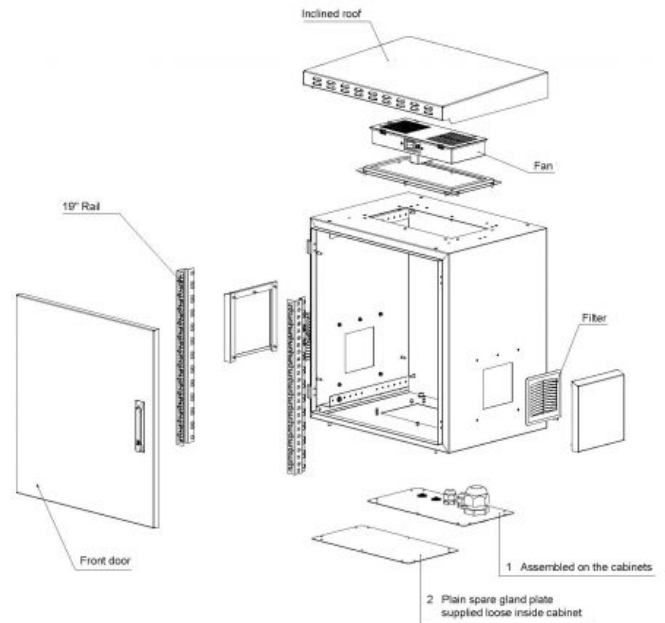

EQUIP NUMBER	EQUIP CODE	HEIGHT	WIDTH	DEPTH	COLOR
280201	ESO-07-6045-G	7U	60	45	Grey
280202	ESO-07-6060-G			60	
280203	ESO-09-6045-G	9U		45	
280204	ESO-09-6060-G			60	
280205	ESO-12-6045-G	12		45	
280206	ESO-12-6060-G			60	
280207	ESO-16-6045-G	16		45	
280208	ESO-16-6060-G			60	
280209	ESO-20-6045-G	20		45	
280210	ESO-20-6060-G			60	
280211	ESO-22-6060-G	22		60	

# Cabinet Accessories Section

---

Equip offers an extensive range of direct cabinet accessories designed to enhance the functionality and organization of your server environments. Our selection includes everything from durable shelves and efficient cooling fans to secure drawers, all crafted to support your infrastructure's needs. With Equip, you can ensure that every component in your server cabinet is optimized for accessibility, cooling, and organization, helping maintain peak performance.

These cabinets are ideal for locations exposed to environmental elements like rain, dust, sleet, snow, and splashing water. For more flexibility, these cabinets can be paired with a plinth for standalone setups. When using the plinth, rear mounting holes can be sealed using plugs sourced from the cabinet's base.





## CASTOR WHEELS AND FEET



280897	EZW-2	for Basic and Dynamic Flex
280896	EZW-1	for Eco and Pro Mount
280895	EZF-1	Feet for Cabinets

## COLLING FANS



280808	EZF-4-G	19", 1U, 4 Fans, Grey
280807	EZF-4-B	19", 1U, 4 Fans, Black
280802	EZF-2-G	19", 1U, 2 Fans, Grey
280801	EZF-2-B	19", 1U, 2 Fans, Black

## RAILS



280832	EZR-DIN-4	19" 4U DIN Rail
280892	EZR-DIN-3	19" 3U DIN Rail
280831	EZR-80/10	19" 800 to 1000mm Depth
280830	EZR-60-80	19" 600 to 800mm Depth

## PLINTHS



280864	EZP-8012-G	800 x 1200m, Grey
280863	EZP-8010-G	800 x 1200m, Grey
280865	EZP-8080-G	800 x 800m, Grey
280862	EZP-6080-G	600 x 800m, Grey
280861	EZP-6060-G	600 x 600m, Grey
280860	EZP-6060-B	600 x 600m, Black

## GROUNDING KIT AND SCREW SETS



280893	EZG-6	6 Connections, 220mm
280894	EZG-24	24 Connections, 780MM

# Panels

## 19" CAT.5E PANELS

## 19" CAT.6A PANELS



326524	24-Port, Shielded, HQ , Light Grey
326525	24-Port, Shielded, Light Grey
326624	24-Port, Unshielded, HQ, Black
326625	24-Port, Shielded, Black



235316	16-Port, Unshielded, Black
235324	24-Port, Unshielded, HQ, Black
235325	24-Port, Unshielded, Black
327316	16-Port, Shielded, Light Grey
327324	24-Port, Shielded, HQ , Light Grey
327325	24-Port, Shielded, Black

## 19" CAT.6 PANELS

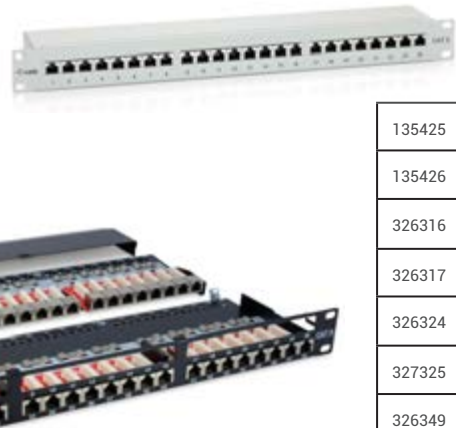

135425	24-Port, Unshielded, Black
135426	24-Port, Unshielded, Black
326316	16-Port, Shielded, HQ , Light Grey
326317	16-Port, Shielded, Light Grey
326324	24-Port, Shielded, HQ , Light Grey
327325	24-Port, Shielded, Light Grey
326349	48-Port, Shielded, Light Grey
326416	16-Port, Shielded, HQ, Black
326417	16-Port, Shielded, Black
326424	24-Port, Shielded, HQ, Black
326425	24-Port, Shielded, Black
326448	48-Port, Shielded, HQ, Black
326449	48-Port, Shielded, Black

## 19" CAT.6 KEYSTONE PANELS



767124	24-Port, 1U, Shielded, Light Grey
769124	24-Port, 1U, Shielded, Black
769224	24-Port, 1U, Unshielded, Black
769248	48-Port, 1U, Unshielded, Black
769258	48-Port, 1U, Unshielded, Black
769349	48-Port, 2U, Shielded, Black

## 19" CAT.6A KEYSTONE PANELS



769225	24-Port, 1U, Unshielded, Black
769324	24-Port, 1U, Shielded, Black

## 19" BRUSH PANELS



327411	19", 1U, Black
327412	19", 1U, Light Grey
327413	19", 1U, Black
327414	19", 1U, Light Grey

## 19" BLANK PANELS



327503	1U, Light Grey
327504	1U, Light Grey
327505	1U, Toolfree, Black
327512	2U, Black
327513	3U, Black
327514	3U, Light Grey
327515	4U, Black
327516	4U, Light Grey

## 10" PATCH PANELS



208015	24-Port, Shielded, HQ, Light Grey
208017	24-Port, Shielded, Light Grey
208014	24-Port, Unshielded, HQ, Black
326623	24-Port, Shielded, Black
326523	Cat.6A, 12-Port, 1U, Shielded, Light Grey

# PDU

## 19" PDUs WITH SWITCH



333283	8-Outlet, German
333285	8-Outlet, French
333286	8-Outlet, German, C14 Plug
333293	8-Outlet, German
333309	7-Outlet, Surge Protection, German
333312	6-Outlet, Circuit Breaker, German
333317	6-Outlet, Line Filter, Surge Protection, German

## 19" PDUs



333282	19", 9-Outlet, German
333292	19", 9-Outlet, German
333313	19", 8-Outlet, French
333315	19", 7-Outlet, 1x USB, German

## IEC PDUs



333280	3-Outlet, C14 Plug
333281	19", 8-Outlet, C13
333310	19", 8-Outlet, C13
333316	19", 8-Outlet, C13 + C19

## 10" PDUs



333299	3-Outlet, German
333302	3-Outlet, French
333311	4-Outlet, German

# Shelves + Drawers

## 19" FIXED SHELVES



280620	EZFS-19-2-80-G	19", 2U, 800mm, Grey
280619	EZFS-19-2-80-B	19", 2U, 800mm, Black
280618	EZFS-19-1-60-B	19", 1U, 600mm, Black
280617	EZFS-19-1-40-G	19", 1U, 400mm, Grey
280616	EZFS-19-1-40-B	19", 1U, 400mm, Black

## 19" VARIABLE SHELVES



280611	EZVS-19-1-50-G	19", 1U, 500mm, Grey
280610	EZVS-19-1-50-B	19", 1U, 500mm, Black
280609	EZVS-19-1-35-G	19", 1U, 350mm, Grey
280608	EZVS-19-1-35-B	19", 1U, 350mm, Black
280607	EZVS-19-1-10-G	19", 1U, 1000mm, Grey
280606	EZVS-19-1-10-B	19", 1U, 1000mm, Black

## 19" SLIDING SHELVES



280604	EZVS-19-1-80-G	19", 1U, 800mm, Grey
280603	EZVS-19-1-80-B	19", 1U, 800mm, Black
280602	EZVS-19-1-60-G	19", 1U, 600mm, Grey
280601	EZVS-19-1-60-B	19", 1U, 600mm, Black

## KEYBOARD DRAWERS



260410	19", Empty, Light Grey
260420	19", Empty, Black
260611	19", DE Keyboard + Trackball, Light Grey
260612	19", US Keyboard + Trackball, Light Grey
260621	19", DE Keyboard + Trackball, Black
260622	19", US Keyboard + Trackball, Black
261611	19", US Keyboard + Touchpad, Light Grey
261612	19", DE Keyboard + Touchpad, Light Grey
261621	19", US Keyboard + Touchpad, Black
261622	19", DE Keyboard + Touchpad, Black

## 10" FIXED SHELVES



280615	EZFS-10-1-20-G	10", 1U, 200mm, Grey
280614	EZFS-10-1-20-B	10", 1U, 200mm, Black
280613	EZFS-10-1-15-G	10", 1U, 200mm, Grey
280612	EZFS-10-1-15-B	10", 1U, 150mm, Black





[www.equip-info.net](http://www.equip-info.net)

Distributed By:

Technical specifications are subject to change without notice.  
© Copyright Digital Data Communications GmbH. All Rights Reserved. Im  
Defdahl 10F, 44141 Dortmund, Germany

2024.02 EN